

OLD TOWN LEANDER

FOR LEASE

2,785+ SQ FT



PROPERTY DETAILS

103 ATKIN STREET | LEANDER, TX 78641

103 Atkin Street will be a modern commercial space coming soon to Old Town Leander

Located just a few feet from Highway 183 (Bell Blvd.), this property has great access, visibility, and will be a cornerstone for the Old Town District of Leander for many years to come.

The property will be suitable for an array of businesses including restaurant, bar, boutique retail, office, coffee shop, or many other specialties. Interior buildout can be completely customized for Tenant's needs.

Building exterior will feature a modern touch with a combination of materials including, glass, natural woods, and metal. The future tenant will enjoy the exclusive use of a shaded outdoor area that can be utilized for outdoor seating or recreational purposes.

AVAILABILITY | 2,785+ SQ FT

RENTAL RATE | \$29.00 per SQ FT + NNNs

EXCLUSIVE

OUTDOOR AREA | Approx. 1,300 SQ FT

ZONING | T5 – Urban Center Zone

*Zoning allows for alcohol sales with approval

TI ALLOWANCE | NEGOTIABLE

Mason Turner | Broker | 512.930.2800 | mason@turnerprop.com
John Woellner | Associate | 512.825.2532 | john@turnerprop.com

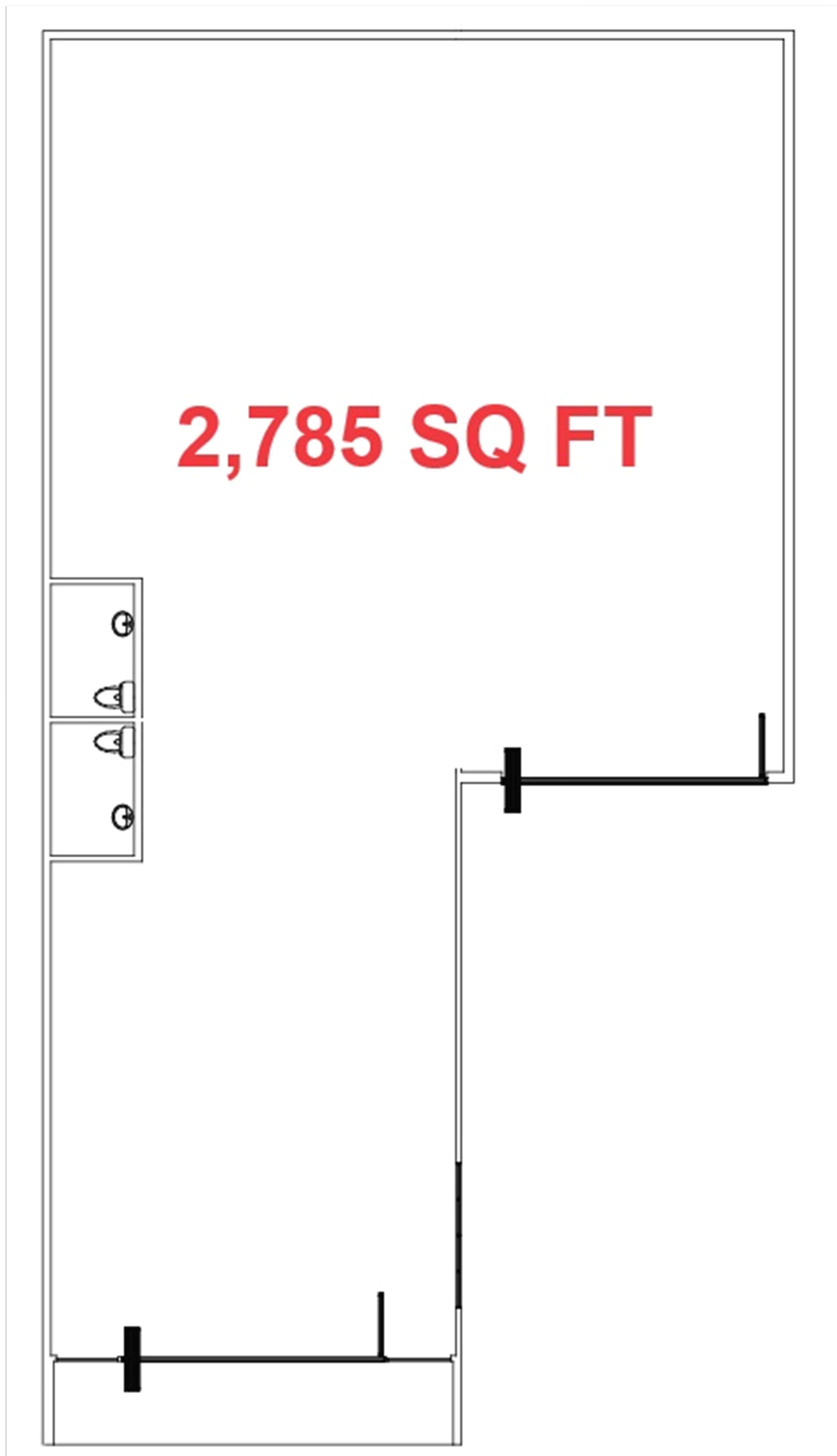

FOR LEASE | 2,785+ SQ FT

Mason Turner | Broker | 512.930.2800 | mason@turnerprop.com
John Woellner | Associate | 512.825.2532 | john@turnerprop.com





LEANDER SMARTCODE

TABLE 6F. SPECIFIC FUNCTION & USE

Table 6F: Specific Function & Use. This table expands the categories of Table 6E to delegate specific functions and uses within Transect Zones.

	T1	T2	T3	T4	T5	T6	SD
c. OFFICE							
Office Building				■	■	■	□
Live-Work Unit			■	■	■	■	□
d. RETAIL							
Open-Market Building		■	■	■	■	■	■
Retail Building				■	■	■	□
Display Gallery				■	■	■	□
Cafe / Restaurant			□	■	■	■	□
Kiosk				■	■	■	□
Push Cart					□	□	□
Liquor Selling Establishment					□	□	□

■ BY RIGHT
□ BY WARRANT

[Transit-Oriented Development District Plan](#)

[Leander SmartCode](#)

This property is being offered in its "AS IS, WHERE IS" condition. The Broker is submitting the attached information in its capacity as a representative of the owner. The material contained herein was obtained from sources deemed reliable. Turner Commercial Properties LLC makes no warranty, express or implied, as to the accuracy of the information contained herein. All presented information submitted is subject to change without notice as regards price, terms or availability. Nothing contained herein should be relied upon as a promise or representation as to the future. Recipients should conduct their own investigation and analysis of the transaction described herein.

OLD TOWN LEANDER

FOR LEASE

2,785+ SQ FT

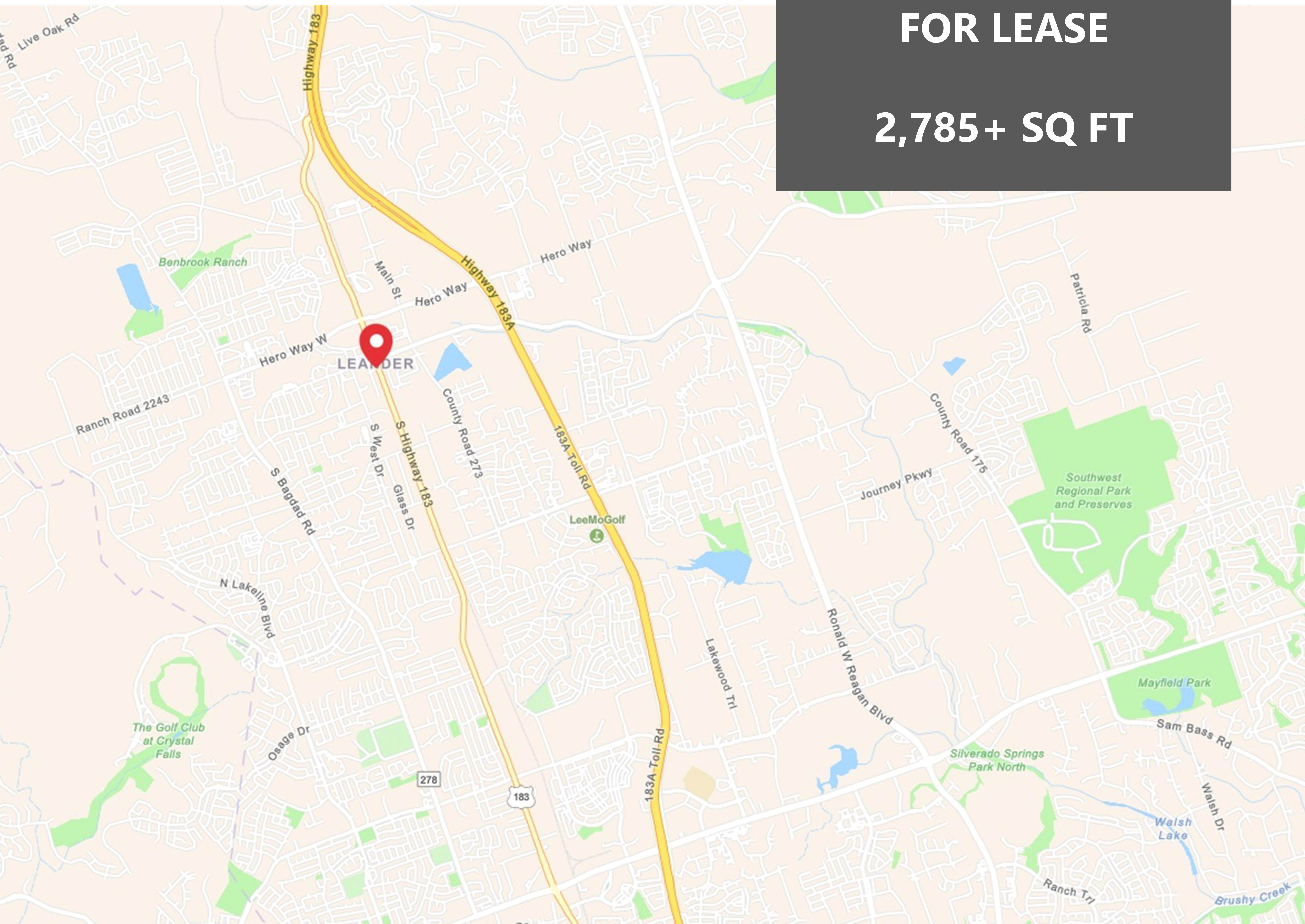

LOCATION

103 ATKIN STREET | LEANDER, TX 78641

Located in Old Town Leander near the intersection of Bell Blvd. (HWY 183) & Atkin St.

Approx. 1 mile west of 183A Toll Road

Approx. 4 miles north of Whitestone Blvd. (FM 1434)

For more information about the growth of Old Town Leander please visit: [Leander Old Town Master Plan](#)

Mason Turner | Broker | 512.930.2800 | mason@turnerprop.com
John Woellner | Associate | 512.825.2532 | john@turnerprop.com

Figure 2.6 shows the Old Town Leander Market Area. As this region grows, there will be an increase in demand for diverse activities to attract new people and new ideas. This growth will impact future needs of the Old Town Study Area. **Figure 2.7** displays the racial makeup of the Old Town Market Area. As of 2020, most of the residents that live within the area are white (78 percent), followed by 16 percent of the residents being two or more races, 10 percent being another race and 5 percent being Black or African American. 33.3 percent of residents in the Market Area are of Hispanic origin. The Diversity Index provides a score between 0 to 100, the percentage represents the likelihood that two people chosen at random are from two different racial groups. The Market Area has a diversity Index of 73.3.

The median age of the people that live in the Old Town Market area is 32.3. This is younger than the median age of the City of Leander (34.7) by two years. 31 percent of the households in the Market Area have children under the age of 18 and the average household size is just under three. Special attention should be made to increase activities for families with young children, as well as younger adults (20s – 30s) with no children. When looking at the region, household sizes and homes with children are larger in the Market Area than in the Austin-Round-Rock Georgetown MSA. Household earnings in Old Town are higher than in the region. The median household income in Old Town Market Area is 90,903 dollars compared to the median household income for the region at 89,278 dollars. Below are more demographic facts about the Old Town Leander Market Area.

Figure 2.6 | Old Town Leander Market Area



Figure 2.7 | Percentage of Population by Race

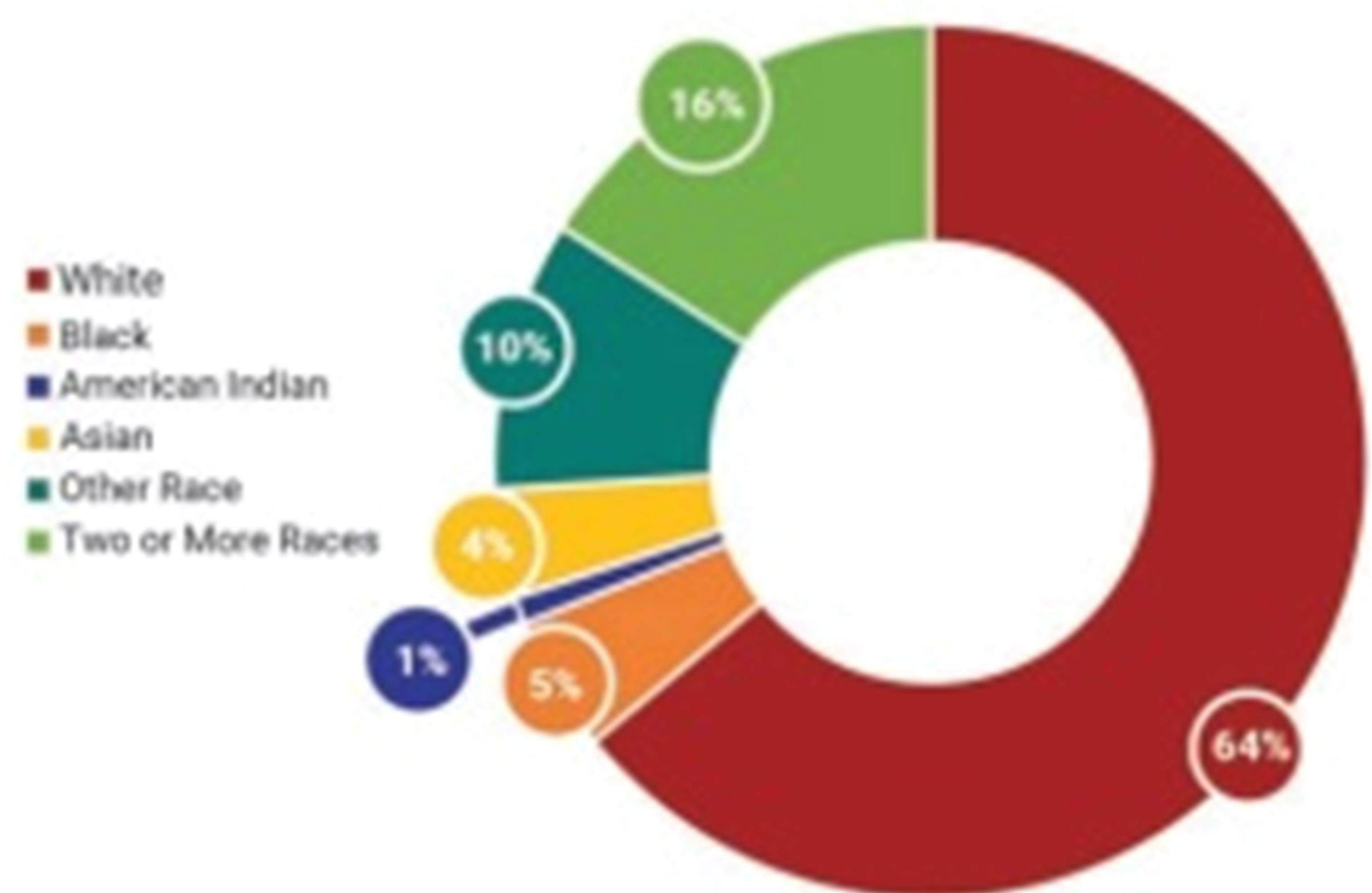

Source: ESRI ACS Key Population & Household Facts (2016-2020)

OLD TOWN MARKET AREA DEMOGRAPHICS

	74.1 Diversity Index		2.53 Average Household Size
	33.3% Hispanic Origin		31% Households with Children under the age of 18
	32.3 Median Age		1% of households with no access to a vehicle
	\$90,903 Median Household Income		33% Adults with Bachelor's Degree

Source: ESRI ACS Key Population & Household Facts (2016-2020)



Information About Brokerage Services

Texas law requires all real estate licensees to give the following information about brokerage services to prospective buyers, tenants, sellers and landlords.

TYPES OF REAL ESTATE LICENSE HOLDERS:

- **A BROKER** is responsible for all brokerage activities, including acts performed by sales agents sponsored by the broker.
- **A SALES AGENT** must be sponsored by a broker and works with clients on behalf of the broker.

A BROKER'S MINIMUM DUTIES REQUIRED BY LAW (A client is the person or party that the broker represents):

- Put the interests of the client above all others, including the broker's own interests;
- Inform the client of any material information about the property or transaction received by the broker;
- Answer the client's questions and present any offer to or counter-offer from the client; and
- Treat all parties to a real estate transaction honestly and fairly.

A LICENSE HOLDER CAN REPRESENT A PARTY IN A REAL ESTATE TRANSACTION:

AS AGENT FOR OWNER (SELLER/LANDLORD): The broker becomes the property owner's agent through an agreement with the owner, usually in a written listing to sell or property management agreement. An owner's agent must perform the broker's minimum duties above and must inform the owner of any material information about the property or transaction known by the agent, including information disclosed to the agent or subagent by the buyer or buyer's agent.

AS AGENT FOR BUYER/TENANT: The broker becomes the buyer/tenant's agent by agreeing to represent the buyer, usually through a written representation agreement. A buyer's agent must perform the broker's minimum duties above and must inform the buyer of any material information about the property or transaction known by the agent, including information disclosed to the agent by the seller or seller's agent.

AS AGENT FOR BOTH - INTERMEDIARY: To act as an intermediary between the parties the broker must first obtain the written agreement of each party to the transaction. The written agreement must state who will pay the broker and, in conspicuous bold or underlined print, set forth the broker's obligations as an intermediary. A broker who acts as an intermediary:

- Must treat all parties to the transaction impartially and fairly;
- May, with the parties' written consent, appoint a different license holder associated with the broker to each party (owner and buyer) to communicate with, provide opinions and advice to, and carry out the instructions of each party to the transaction.
- Must not, unless specifically authorized in writing to do so by the party, disclose:
 - that the owner will accept a price less than the written asking price;
 - that the buyer/tenant will pay a price greater than the price submitted in a written offer; and
 - any confidential information or any other information that a party specifically instructs the broker in writing not to disclose, unless required to do so by law.

AS SUBAGENT: A license holder acts as a subagent when aiding a buyer in a transaction without an agreement to represent the buyer. A subagent can assist the buyer but does not represent the buyer and must place the interests of the owner first.

TO AVOID DISPUTES, ALL AGREEMENTS BETWEEN YOU AND A BROKER SHOULD BE IN WRITING AND CLEARLY ESTABLISH:

- The broker's duties and responsibilities to you, and your obligations under the representation agreement.
- Who will pay the broker for services provided to you, when payment will be made and how the payment will be calculated.

LICENSE HOLDER CONTACT INFORMATION: This notice is being provided for information purposes. It does not create an obligation for you to use the broker's services. Please acknowledge receipt of this notice below and retain a copy for your records.

Turner Commercial Properties, LLC	9014779	info@turnerprop.com	(512)930-2800
Licensed Broker /Broker Firm Name or Primary Assumed Business Name	License No.	Email	Phone
Mason Turner	663187	mason@turnerprop.com	(512)930-2800
Designated Broker of Firm	License No.	Email	Phone
Licensed Supervisor of Sales Agent/ Associate	License No.	Email	Phone
Sales Agent/Associate's Name	License No.	Email	Phone
Buyer/Tenant/Seller/Landlord Initials		Date	

Regulated by the Texas Real Estate Commission

Information available at www.trec.texas.gov