

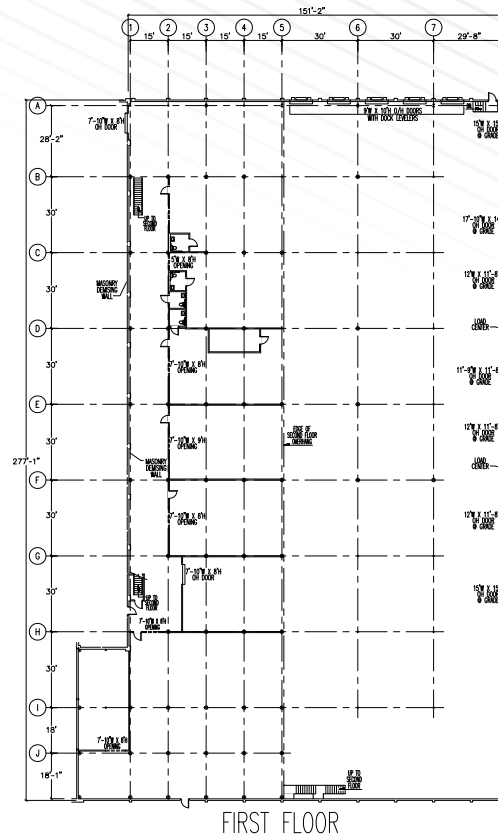

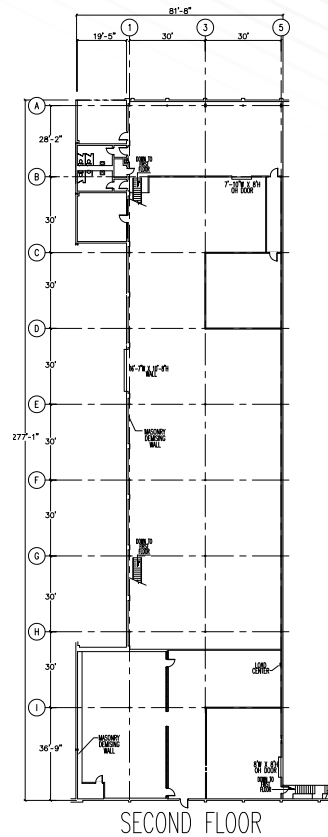

# 15026 RONNIE DR

64,775 SF | DIVISIBLE TO 8,000 SF | VACANT (30 DAYS)



**JESSICA MIZRAHI, SIOR**  
Managing Director  
813 204 5323  
jessica.mizrahi@cushwake.com

**TREY CARSWELL, SIOR**  
Managing Director  
813-230-6131  
trey.carswell@cushwake.com

**LISA ROSS, SIOR**  
Managing Director  
813 424 3211  
lisa.ross@cushwake.com

**SAM KOROLOS**  
Associate  
704 989 1327  
sam.korolos@cushwake.com



**CUSHMAN & WAKEFIELD**

# 15050 DAWSON DR

39,346 SF | VACANT

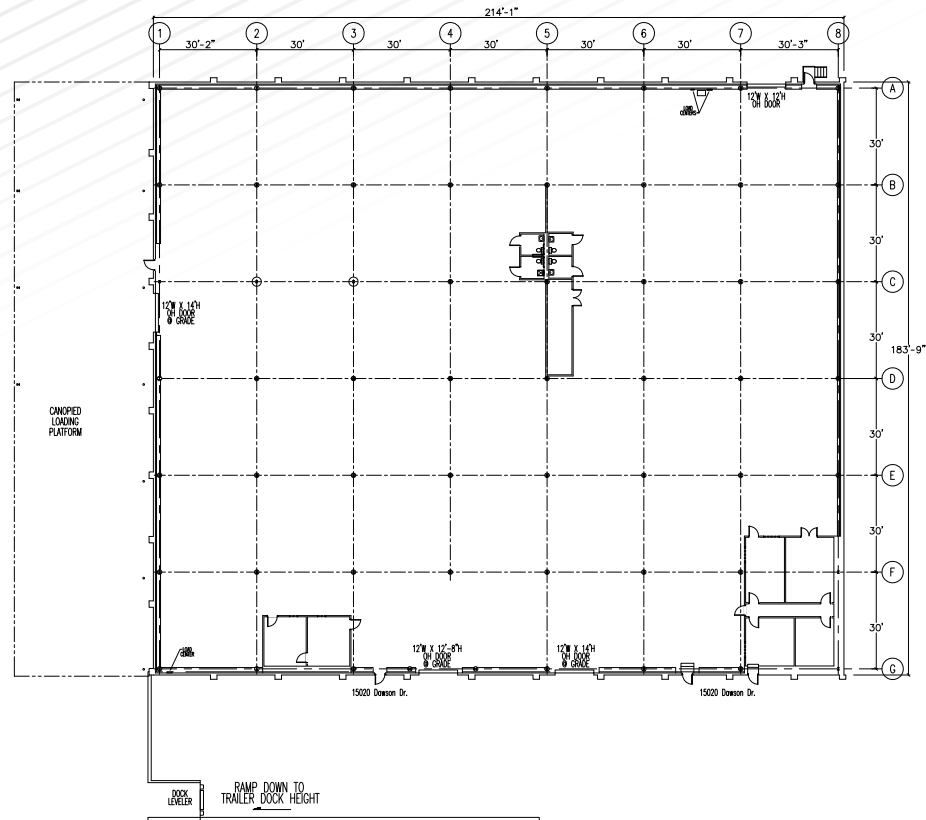

**JESSICA MIZRAHI, SIOR**  
Managing Director  
813 204 5323  
jessica.mizrahi@cushwake.com

**TREY CARSWELL, SIOR**  
Managing Director  
813-230-6131  
trey.carswell@cushwake.com

**LISA ROSS, SIOR**  
Managing Director  
813 424 3211  
lisa.ross@cushwake.com

**SAM KOROLOS**  
Associate  
704 989 1327  
sam.korolos@cushwake.com



**CUSHMAN & WAKEFIELD**

# 15000 RONNIE DR

25,000 SF | VACANT

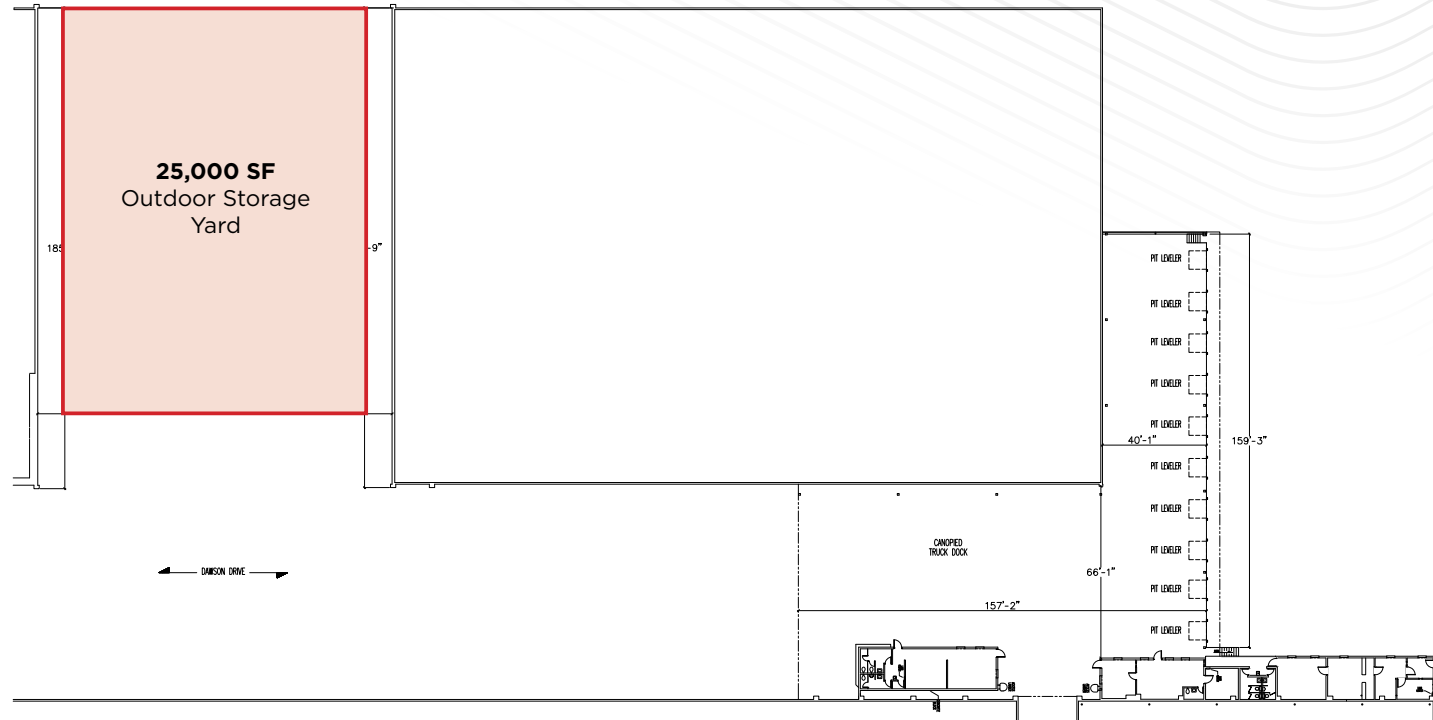

**JESSICA MIZRAHI, SIOR**  
Managing Director  
813 204 5323  
jessica.mizrahi@cushwake.com

**TREY CARSWELL, SIOR**  
Managing Director  
813-230-6131  
trey.carswell@cushwake.com

**LISA ROSS, SIOR**  
Managing Director  
813 424 3211  
lisa.ross@cushwake.com

**SAM KOROLOS**  
Associate  
704 989 1327  
sam.korolos@cushwake.com



# 14910 CITRUS COUNTY DR

25,000 SF | VACANT

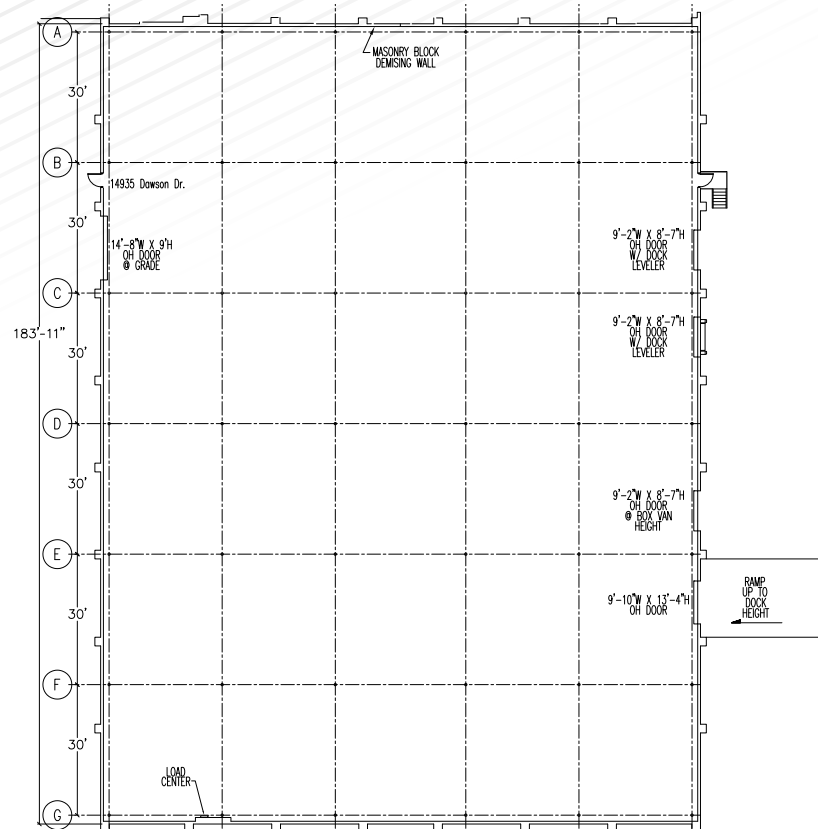

**JESSICA MIZRAHI, SIOR**  
Managing Director  
813 204 5323  
jessica.mizrahi@cushwake.com

**TREY CARSWELL, SIOR**  
Managing Director  
813-230-6131  
trey.carswell@cushwake.com

**LISA ROSS, SIOR**  
Managing Director  
813 424 3211  
lisa.ross@cushwake.com

**SAM KOROLOS**  
Associate  
704 989 1327  
sam.korolos@cushwake.com





# 37912-37916 CARGILL WAY

10,000 SF | VACANT (30 DAYS)

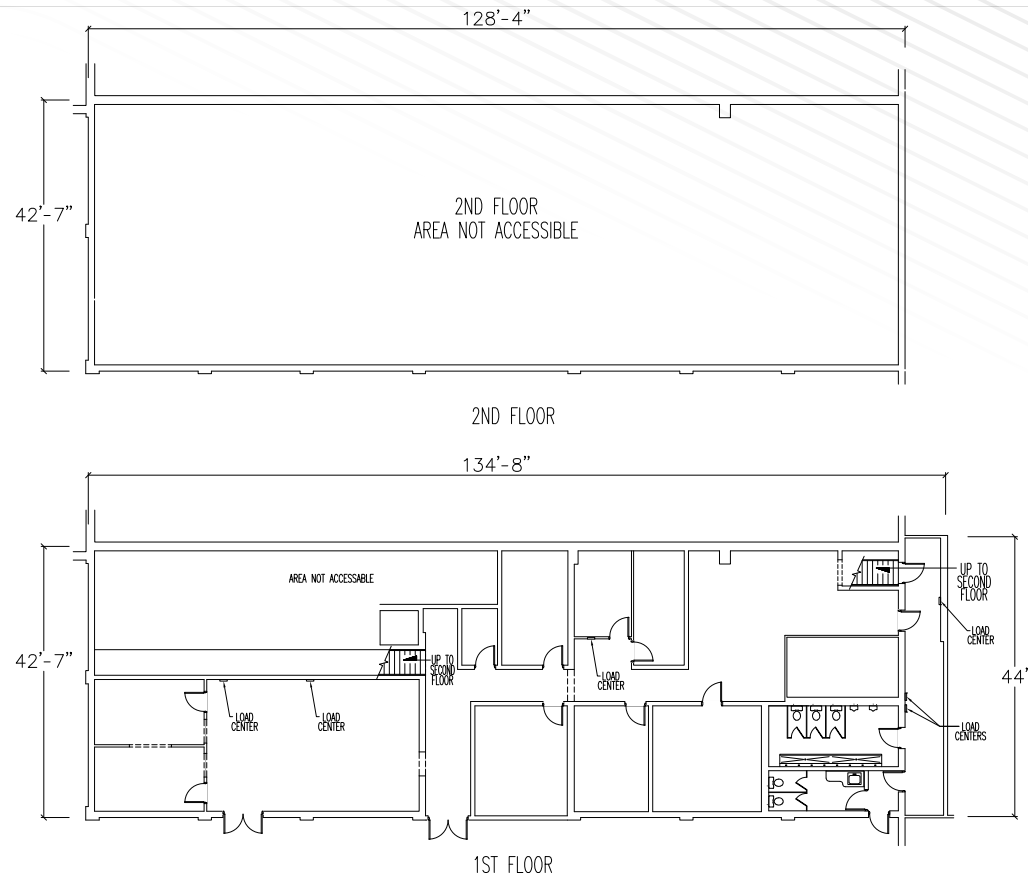

**JESSICA MIZRAHI, SIOR**  
Managing Director  
813 204 5323  
jessica.mizrahi@cushwake.com

**TREY CARSWELL, SIOR**  
Managing Director  
813-230-6131  
trey.carswell@cushwake.com

**LISA ROSS, SIOR**  
Managing Director  
813 424 3211  
lisa.ross@cushwake.com

**SAM KOROLOS**  
Associate  
704 989 1327  
sam.korolos@cushwake.com



# 15112 CITRUS COUNTY DR

9,157 SF | VACANT (30 DAYS)

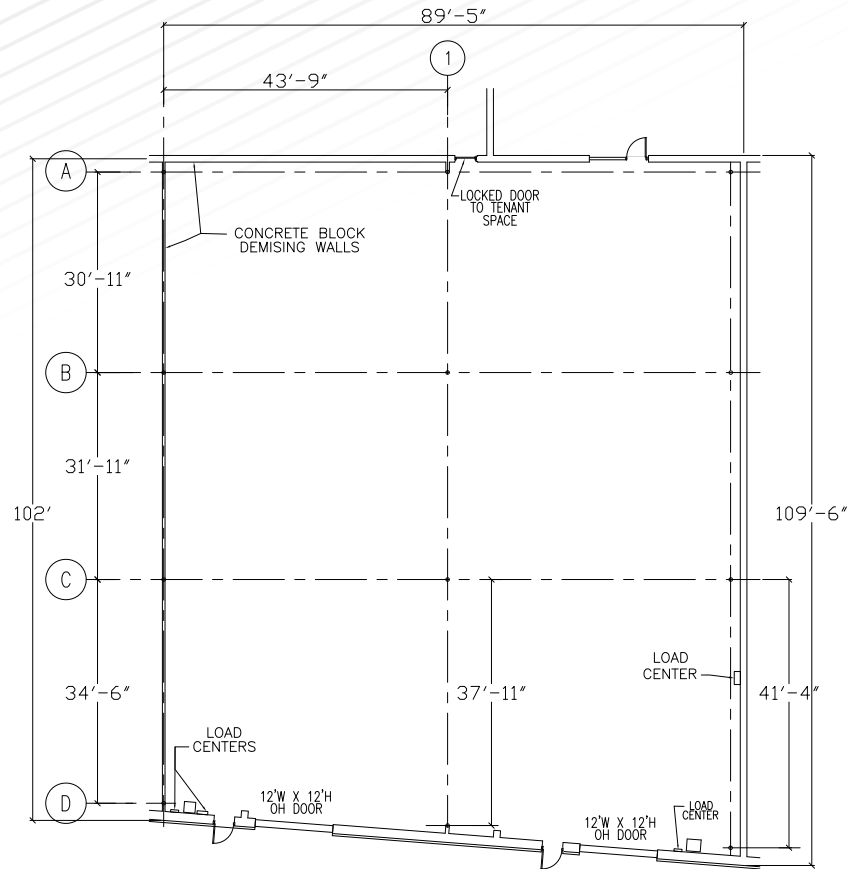

**JESSICA MIZRAHI, SIOR**  
Managing Director  
813 204 5323  
jessica.mizrahi@cushwake.com

**TREY CARSWELL, SIOR**  
Managing Director  
813-230-6131  
trey.carswell@cushwake.com

**LISA ROSS, SIOR**  
Managing Director  
813 424 3211  
lisa.ross@cushwake.com

**SAM KOROLOS**  
Associate  
704 989 1327  
sam.korolos@cushwake.com



**CUSHMAN & WAKEFIELD**



# 37910 VITALITY WAY

4,532 SF | VACANT (30 DAYS)

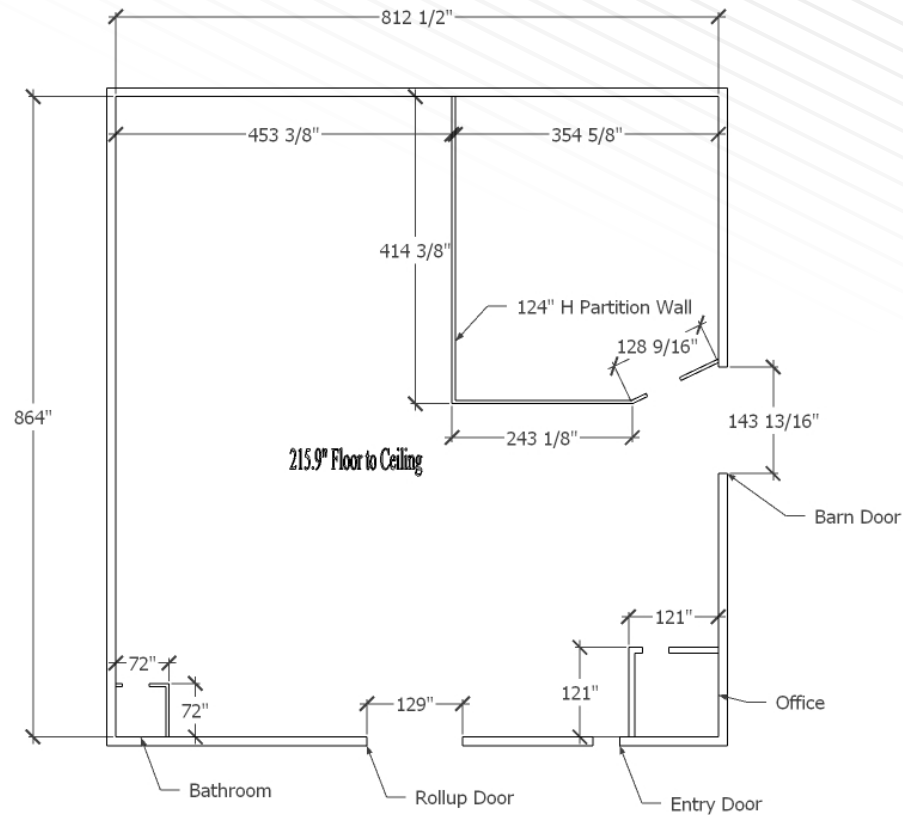

**JESSICA MIZRAHI, SIOR**  
Managing Director  
813 204 5323  
jessica.mizrahi@cushwake.com

**TREY CARSWELL, SIOR**  
Managing Director  
813-230-6131  
trey.carswell@cushwake.com

**LISA ROSS, SIOR**  
Managing Director  
813 424 3211  
lisa.ross@cushwake.com

**SAM KOROLOS**  
Associate  
704 989 1327  
sam.korolos@cushwake.com

