

WOLF

REALTY, INC.



14021 N. 51st Ave, Ste 114 • Glendale, AZ 85306-4840
Phone: (602) 843-5200 • FAX: (602) 843-5718

LEASE OPPORTUNITY

18206 North 19th Avenue

19th & Union Hills

Zoning: C-1

Parking: 30

Traffic Count: 29,000 vpd

-] Landscaped and Well Maintained
-] Great Location Easy Ingress / Egress
-] Built-out move-in ready
-] Northern orientation
-] Owner Maintains Air Conditioning
-] Each Suite Has Private Restrooms
-] Cox & Century Link service building
-] Owner Will Consider Short Term Leases

Suite 2A, 950 sqft, 3 offices, open bullpen, and private restroom, and storage.

Second floor \$12.50/ sqft Modified Gross

(Move-in ready)

Northern glass line, ample parking, good freeway access, good neighbors, and good owner. Lets make your next office here!

CALL LISTER FOR SHOWINGS.

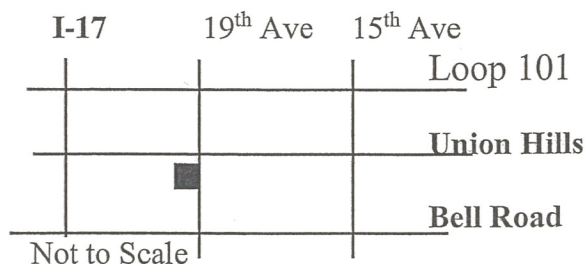

Not to Scale

SCOT E. HALL
BROKER
WOLF REALTY, INC.
14021 N. 51st Avenue #114
Glendale, AZ 85306
(602) 843-5200

18206 North 19th Avenue, Phoenix, AZ. 85023

No scale, Measurements are approximate

Suite 2A

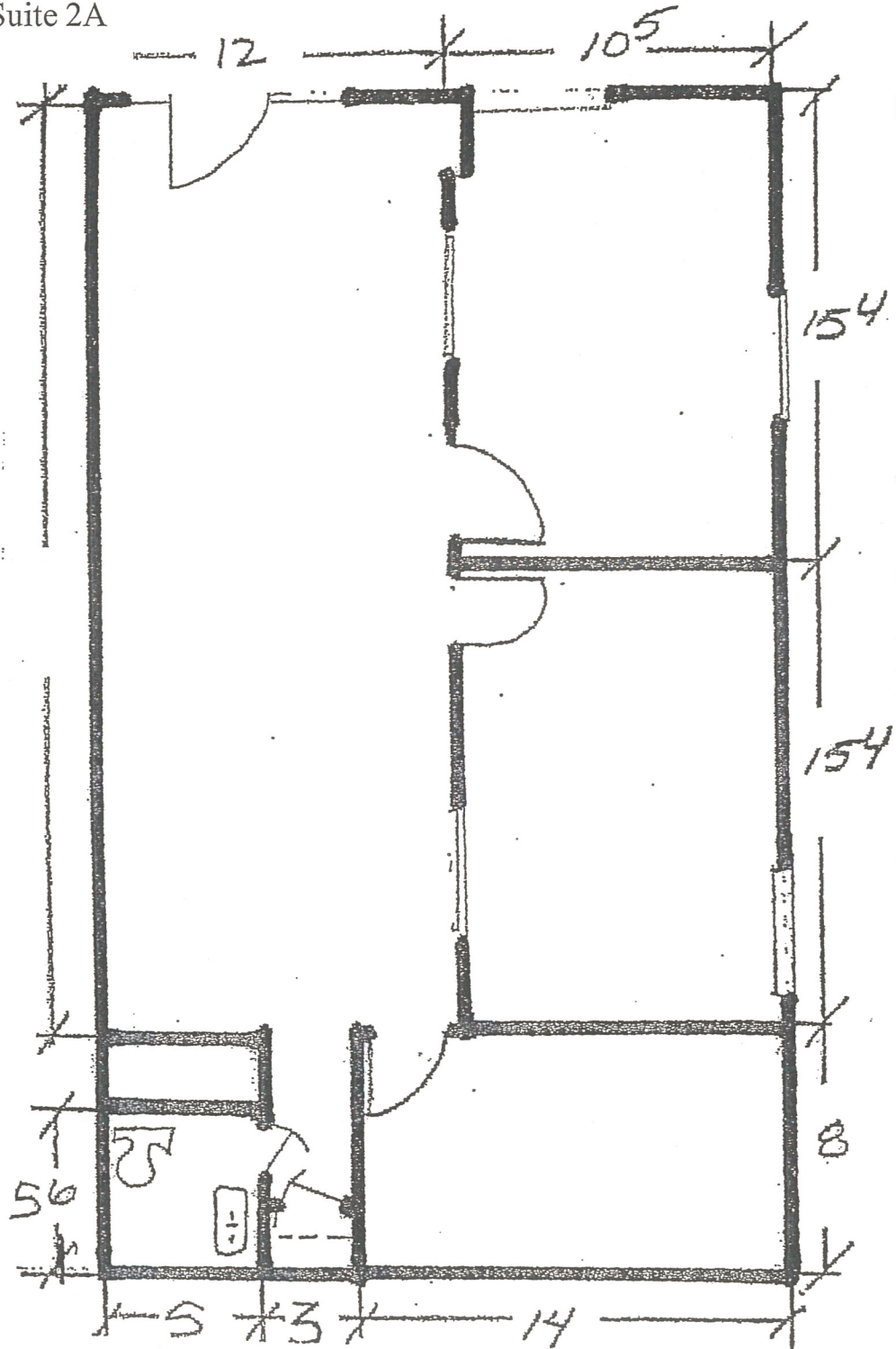

Information furnished is from sources deemed reliable. We have no reason to doubt it's accuracy, but we do not guarantee it. Purchaser should independently verify all information. This offering is submitted subject to errors and omissions, change in price, sale, financing and/or withdrawal without notice.